

***XE3000 Development Kit
Users Guide
Development kit for the XE3000 Series
Ultra low-power CODECs***

Table of Contents

1	INTRODUCTION	3
2	CONTENTS OF THE DEVELOPMENT KIT.....	3
3	GETTING STARTED	3
3.1	GETTING STARTED WITH THE BATTERY-OPERATED DEMONSTRATOR	3
3.2	GETTING STARTED IN THE LAB	4
4	OPERATING THE DEV KIT FROM A PC FOR EVALUATION PURPOSES	5
4.1	STARTING WITH THE SOFTWARE	5
4.2	XE3000DVK BOARD INITIALISATION	5
4.3	CODEC CONFIGURATION	6
5	CONNECTING THE DEVELOPMENT KIT TO A CD PLAYER.....	6
6	CONNECTING A SPEAKER TO THE DEVELOPMENT KIT	7
7	DESCRIPTION OF THE XE3000 DEVELOPMENT KIT	7
7.1	OVERVIEW	7
7.2	XE3006.....	7
7.3	SYSTEM CONTROL	7
7.4	SUPPLY.....	8
7.5	ONBOARD ELECTRET MICROPHONE.....	8
7.6	ANALOG OUTPUT	8
7.7	DIGITAL AUDIO INPUT	8
7.8	CLOCK SELECTION.....	8
8	EMULATION OF OTHER MEMBERS OF THE XE3000 FAMILY.....	9
9	APPENDIXES.....	9
9.1	DEFINITION OF THE DEVELOPMENT KIT	9
	VIEW OF THE XE3000DVK BOARD	10
9.3	TOP SCHEMATIC	11

TABLE OF FIGURES

<i>FIGURE 1: CONNECTING THE DEVELOPMENT KIT TO THE PC</i>	<i>4</i>
<i>FIGURE 2: VIEW OF THE COM PORT SETUP</i>	<i>5</i>
<i>FIGURE 3: THE GRAPHICAL USER INTERFACE GUI.....</i>	<i>6</i>
<i>FIGURE 4: GENERAL VIEW OF THE DEVELOPMENT KIT</i>	<i>7</i>
<i>FIGURE 5 : XE3000DVK BOARD LAYOUT</i>	<i>10</i>

HARD- AND SOFTWARE REFERENCES:

<i>DEVELOPMENT BOARD:</i>	<i>XE3000 PCB-E003V1A</i>
<i>PC SOFTWARE:</i>	<i>XE3000SWPCV0.9</i>
<i>MICROCONTROLLER XE88LC05 SOFTWARE:</i>	<i>XE3000SWLC05MTPV0.9</i>

1 Introduction

The XE3000 Development Kit allows you to evaluate the electrical as well as the audio performance of the XE3000 series of ultra low power voice/audio conversion products.

This development kit for the XE3000 series of voice and audio converters is equipped with an XE3006 CODEC. The XE3000 series consists of four different devices: the XE3003, 3004, 3005 and 3006. Because the XE3003, 3004 and 3005 are subsets of the XE3006, this kit can be used for evaluating all four devices in the XE3000 series. For details on how to simulate the other devices, please refer to the section 8.

A detailed picture of the Development Kit board with explanations is given in section 9. Throughout this User's Guide, references are made to this picture in square brackets [] in order to identify the component in question on the board.

2 Contents of the development kit

- Board with various interface connectors, a microphone and the XE3006 chip.
- Serial cable RS232 to connect the board to the PC.
- CD containing:
 - software to control the board.
 - full documentation on the XE3000 series products.
- 3 samples of the XE3006 chip.
- Headphone to connect to the board.

3 Getting started

There are 2 ways to operate the development kit:

- 1) as demonstrator with a microphone, XE3006 CODEC and headphone working on a lithium coin cell.
- 2) as a development kit used in the lab to evaluate the performance of the XE3000 products in detail.

Below is a short description of how to get started either way.

3.1 Getting started with the battery-operated demonstrator

To get started with the Development Kit as a demonstrator, working stand alone on a battery, follow these instructions:

1. Place the development kit as described in the picture below (figure 1) with the Xemics logo at the bottom.
2. **Do not connect** the laboratory power supplies [10 and 11].
3. Remove the jumper named "i/E_Vbat" [14].
4. Connect the headphone to the 3.5mm jack with direct output for the codec [18].
5. Insert a lithium coin cell battery in the battery holder [12].
6. Apply the battery power to the development kit by switching switch "sw6" [13] to the "bat" position (down).
7. Push the "reset Ic05" button [15] to reset the entire system and put the XE3006 codec in loopback mode.

Now you can talk into the microphone and hear the analog signal in the headphone, which has been converted, to digital and back to analog. Please note that in this configuration the XE3006 CODEC is used without the additional amplifiers. The microphone is powered by the XE3006 codec and the input amplification is set to the max value (x20, see the XE3006 codec data sheet for more details).

3.2 Getting started in the lab

To get started with the Development Kit in a laboratory setup, follow these instructions.

1. Place the development kit as described in the picture below (figure 1) with the Xemics logo at the bottom.
2. Connect the upper left jack with a +9V supply [10].
3. Connect the lower right pin with a -9V supply [11].
4. Connect the serial cable between the personal computer and connector on the lower left corner [17].
5. Connect a CD, DAT or minidisc reader with a toslink cable to the central toslink connector [16] on the left of the development kit (optional).
6. Connect the headphone to the upper 3.5mm jack [18] for the direct output from the CODEC or the lower 3.5mm jack [19] for the amplified (1W-8ohms) output.
7. Optionally, connect a loudspeaker to the upper right connector [20] on pin 1-2 for the direct output from the CODEC or 2-3 for the amplified output (1W).
8. Install the software as described in the section 4 and read carefully the instructions on how to use the software.
9. Remove the battery.
10. Switch on the power supply.

When using the software, you can observe the communication between the computer and the codec in the "TX line" and "RX line" of the graphical user interface (Figure 3) hereafter referred as "GUI". If no answer is present in the "RX line", check your cable or select the correct COM port (see section 4).

For the default jumper position see section 9.1. If the jumper "I/E_Vbat" [14] has been removed previously, it must be replaced in the default position (up).

Attention! Keep the headphone and/or speaker away from the microphone [2] in order to avoid acoustical feedback.

Figure 1: Connecting the Development Kit to the PC

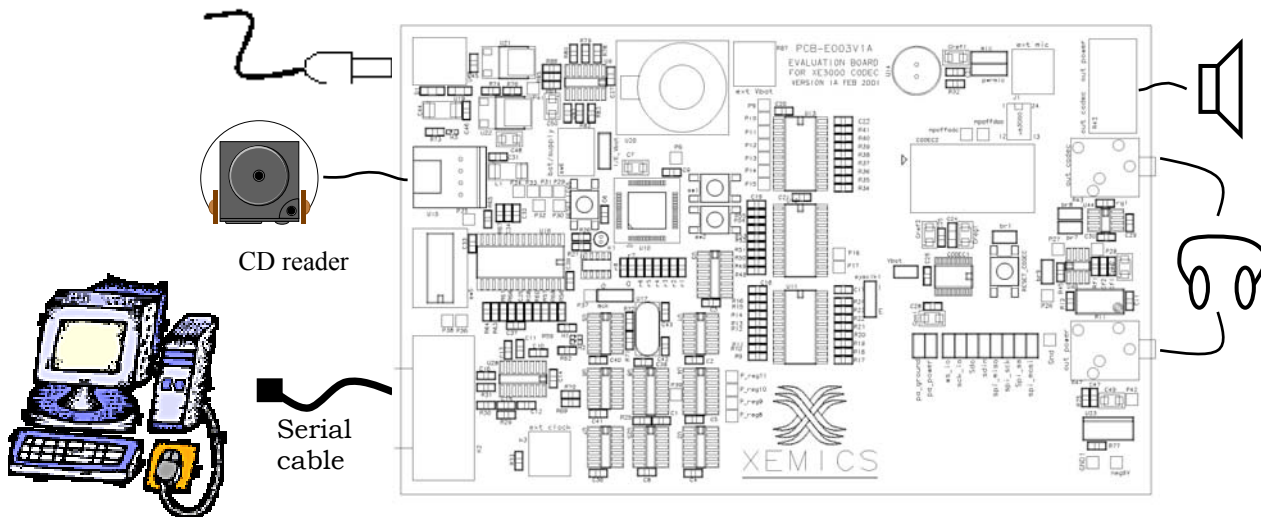

4 Operating the Dev Kit from a PC for evaluation purposes

For PC-controlled operation, the development kit has to be connected as described in the “getting started” instructions and the software must be installed on a personal computer.

To install the software, put the CD-ROM supplied with the kit in a personal computer and copy the folder containing the software on your computer. Run the software by double clicking on the “CodeInterface.exe” icon or you can run the software directly from the CD.

Figure 4 shows the user interface (“GUI”) when the software is started.

4.1 Starting with the software

First set the COM port with the “com setup button” on the main user interface. An interface as shown in Figure 2 will appear. Choose the COM port connected to the development board and set the baud rate to 19200 as shown below:

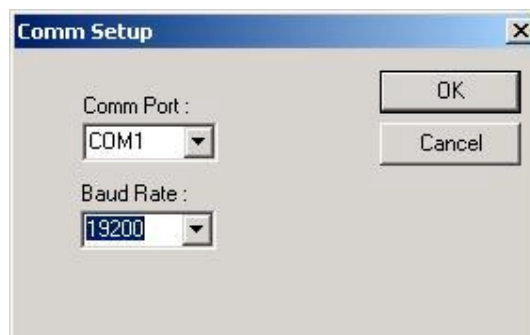

Figure 2: View of the com port setup

4.2 XE3000DVK Board initialisation

The XE3000 codec user interface (Figure 4) is separated in three fields. The Board initialisation on the left, the codec configuration in the center and the registers on the right.

With the “Board Initialisation” on the left side, the XE3000 CODEC audio interface can be set to master or slave mode and three different audio sources can be selected just below.

The XE88LC05 audio source has not yet been implemented. The CD audio source is available if you connect an optical (Toslink) digital source with a S/PDIF format to the connector “U15” [16]. Finally the “other” source puts the optical source in a tristate mode in order to be able to connect a users external source directly to the jumper below the CODEC [6] (the signal levels have to correspond to the CODEC supply voltage level). In this mode the CODEC can receive or send data via the four pin audio interface [6].

When choosing the CD audio source, don’t forget to change the jumper “mck” [7] in order that the master clock comes from the CD source and is adapted to the sampling frequency of the data. Be careful to not use the ADC part of the XE3000 when the sampling frequency is higher than 20Khz.

Under the Audio source, the power supply can be set in the box. The supply can vary between 1.8 to 3.3V in about 0.2V steps. Changing the value in the box immediately changes the supply on the board for the XE3000 codec.

The “Board Initialization” button sets the board in the state chosen in the “Board initialization” part of the “gui”. This is useful when a hardware reset is made or when the board supply has been cut.

4.3 CODEC configuration

The central and the right side of the “GUI” are used to set the CODEC registers.

On the right side, the registers are described in a scroll region that includes the register name, the address, and the default value at power on and finally, the current value. You can select the “current value” field and put a new value in it. To update the XE3006 codec registers, you need to push the “Write CODEC” button on the “GUI”. This action will update all the registers as set in the “current value” field.

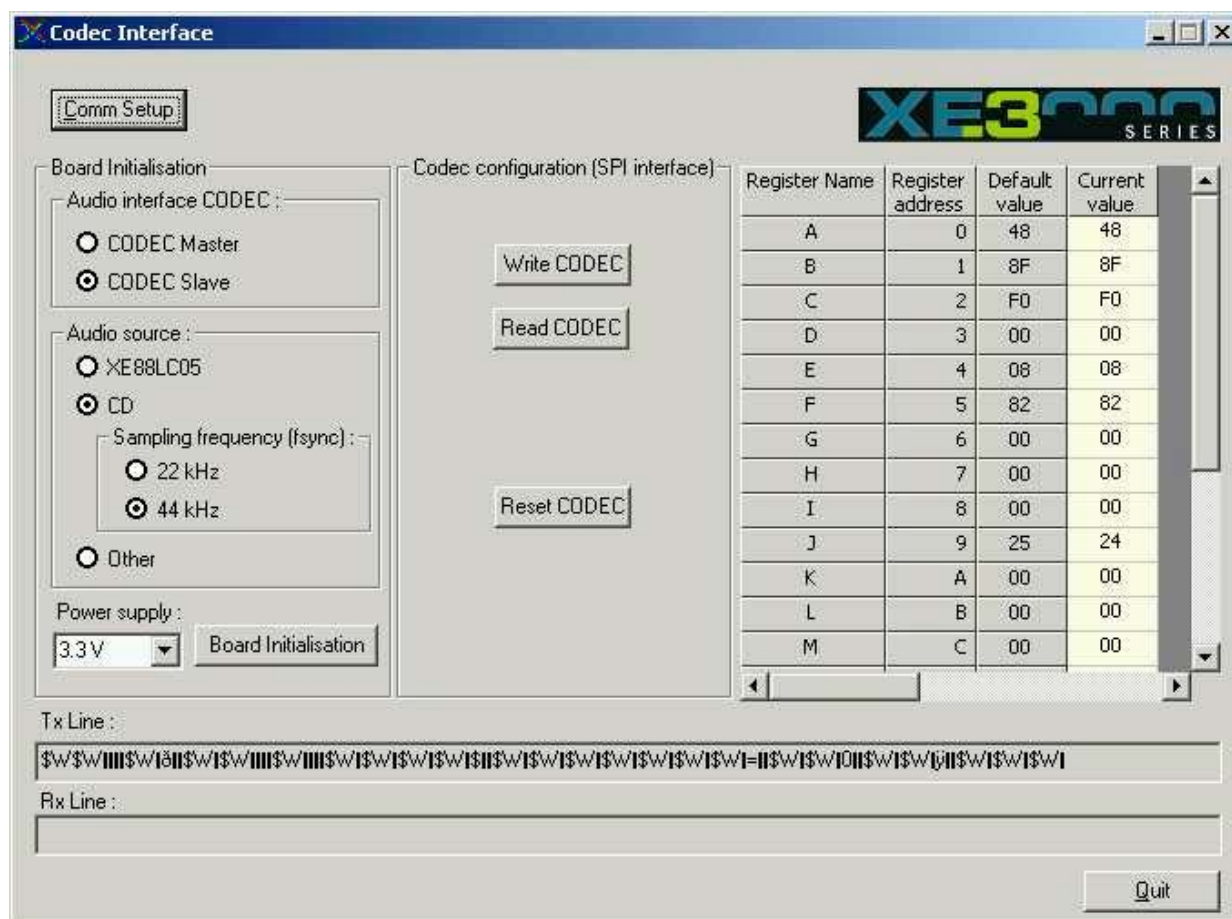

Figure 3: The Graphical User Interface GUI

In the middle section, you will find the buttons, which permit you to update or read all the registers from the CODEC. This is useful in case of power off of the board or in case of reset hardware.

The “Setup file” button is made to load a file with the enable value for the CODEC. Many different settings can be written on different files and then be loaded when needed. When loaded (by clicking “send Wr Cmd”), the CODEC registers are updated automatically. **(not yet available)**.

The “CODEC reset” button has the same function as the hardware reset button. After a “CODEC reset”, the status of the registers is read and displayed on the “GUI”.

5 Connecting the Development Kit to a CD player

An optical cable (TOSLINK) is needed between your digital source and the development kit. The format used is S/PDIF coming from the Philips/Sony standard. Many different digital sources can be used such as minidisc, CD player or DAT.

The CD audio source must be selected on the “GUI” in order to put the CODEC in CD-mode and to start the CD-related part of the board. The “mck” jumper [7] must be on the left side to receive the clock from the CD-source.

6 Connecting a speaker to the Development Kit

The Connector “R42” [20] has been implemented in order to connect a loudspeaker without the need of a special plug. You can fix the wire from the loudspeaker directly into this connector.

7 Description of the XE3000 Development Kit

7.1 Overview

The XE3000 Development kit is designed to allow easy evaluation of the XE3000 series of low power CODECs.

It contains an XE3006 CODEC, a Xemics microcontroller XE88LC05 [22] that controls the board functions such as communication with a personal computer and digital audio interface. The digital audio interface allows you to listen to music from a compact disc player with an optical output, directly through the XE3006 CODEC.

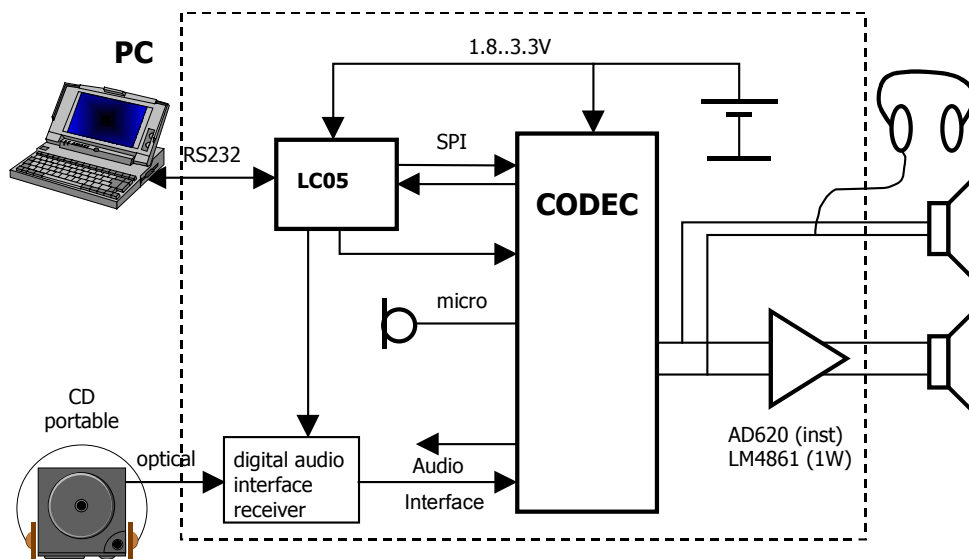

Figure 4: General view of the Development Kit

At start-up, or after a reset, all blocks in the CODEC are running. The LC05 sets the CODEC in loop-back mode if the board is not connected to a personal computer. The preamplifier gain is set to the max value (20x). The output of the kit can be listened to by means of a headphone with or without amplification (direct output from the XE3006 CODEC). Use a headphone with a power control or the one supplied with the kit.

7.2 XE3006

The features and functions of the XE3006 ultra low power CODEC are described in its data sheet.

7.3 System control

The development kit is controlled by a Xemics Microcontroller XE88LC05 [22], which sets the voltage supply value for the XE3006 CODEC, receives the CODEC settings from a personal computer via a serial line (RS232), writes these settings in the CODEC registers. It also enables the data coming from the optical digital audio interface to be converted in the CODEC.

The software enables you to configure the board and the XE3006 CODEC. The graphical user interface (Figure 3) shows all the possibilities available, and the CODEC registers in full view. See Chapter 4 “Operating the Development Kit from a PC for evaluation purposes” for a description of the software functionality.

A “reset Ic05” button [15] is situated near the XE88LC05 [22]. This button resets the entire system to the following state:

- Supply of the CODEC at 3.3V.
- CODEC in loopback mode with maximal gain on the microphone input, MCLK in divided by 1 mode and microphone supply enabled.

After a reset, the state of the “GUI” must be initialized in order to reflect the state of the CODEC as explained in Chapter 4.

7.4 Supply

All the functions are accessible only if the external power supplies are used.

The XE3000 development kit needs a positive power supply of 9 to 15V. The supply is regulated on the board to 5V.

A negative power voltage of -9 to -15V, regulated to -5V, is required in order to use the audio power output.

The supply of the CODEC can vary from 1.8 to 3.3V set by the “GUI” on a personal computer.

An onboard battery holder [12] is also available for a direct test of the CODEC without the personal computer. The switch “sw6” (Bat/Supply) [13] permits you to change between the battery and the main supply. In addition an external Vbat can be connected to the “ext Vbat” connector [12b] and by selecting the Vbat needed with the jumper “I/E Vbat” [14].

7.5 Onboard electret microphone

The onboard microphone [2] allows the user to use the ADC without having to put any additional element to the board. The digital data is sent directly through the DAC and can be heard with the headphone at power up.

The power supply of the microphone can be chosen via the jumper “pwrmic” [5] between the supply given from the CODEC or the variable power source.

An external source can replace the microphone, if wanted, by changing the jumper “mic” [4] and using the smc connector “ext mic” [2b]

7.6 Analog output

If you want to listen directly to the analog CODEC output, you can connect the headphone to the 3.5mm jack plug “R43” (out CODEC) [18] or to the connector “R42” [20] (between 1-2).

If you need an amplified output signal (maximum 1 W), connect to the 3.5mm jack plug “R47” (out power) [19] or to the connector “R42 [20] (between 3-4).

7.7 Digital audio input

On the connector “U15” [16] you can connect a toslink type optical cable coming from a digital audio source like a CD, DAT or minidisc player (S/PDIF). This source can be sent to the DAC part of the CODEC via the audio interface. Two different sampling frequencies can be chosen from the “GUI” (basically 44-48Khz and 22-24Khz) which depends on the sample frequency sent by the source.

In this configuration, the Digital audio interface must become the Master for the CODEC system clock by putting the jumper “mck” [7] to the left.

7.8 Clock selection

Three main sources of clock can be put into the CODEC. The first one comes from an onboard quartz “u17” [21]. The second one comes from the digital audio input. The jumper “mck” permits you to choose between the two clock sources.

The third one is an external source of clock that can be applied to the “ext clock” connector [9]. The voltage level of the external clock should have the same level as the actual supply voltage of the CODEC (e.g. 1.8 V). The jumper “sysclk” [8] select between the “ext clock” [9] or the two other sources of clock[7].

8 Emulation of other members of the XE3000 family

The table below explains which action needs to be carried out in order to “emulate” one of the XE3000 devices.

Device	ADC	DAC	Sandman	Action	Register(s)	Bit #	Value
XE3003	X	-	X	Disable DAC	I	3	1
XE3004	-	X	X	Disable ADC	I	2	1
XE3005	X	X	-	Disable Sandman function	L,M,N,O,P	All	0
XE3006	X	X	X	-	-	-	-

Table 1: Emulation of the XE3003, XE3004, XE3005 with the XE3000DVK

9 Appendixes

9.1 Definition of the development kit

See Figure 5 for reference.

1. XE3006
2. Microphone (in socket, can be replaced by user)
- 2b. ext mic
3. CODEC reset switch
4. Mic jumper : left microphone (default), right ext mic smc connector
5. Pwrmic jumper: left variable supply, right CODEC supply (default)
6. Jumpers for digital signals and CODEC power amplifier supply see on the board the function
7. Mck jumper: left mck from digital audio receiver, right mck from onboard quartz (default)
8. Sysckl jumper: up mck from “mck” jumper (default), down mck from smc connector “ext clock” (see 9)
9. Ext clock: smc connector (put signal level equal to CODEC power supply)
10. Positive supply (+9V DC)
11. Negative supply (-9V DC)
12. 3.3V battery
- 12b. external battery
13. bat or supply switch: up onboard regulated supply (default), down battery
14. internal or external Vbat: up battery (default), down ext Vbat smc connector
15. System reset: restart the entire system to default value
16. TOSLINK connector (S/PDIF): digital audio receiver input
17. RS232 connection with the personal computer
18. 3.5mm jack with direct output from the CODEC
19. 3.5mm jack with output from the power amplifier
20. loudspeaker connector: 2 connection on the bottom for direct output from the CODEC, two upper connection for amplified output
21. X-tal (in socket, can be replaced by user)
22. XE88LC05 microcontroller

9.2 View of the XE3000DVK board

Figure 5 : XE3000DVK board layout

